

## RoadRunner+ 34/45/60:1

These instructions cover the basic gearbox assembly sequence.

For additional information, hints and tips you can refer to our Guidance Section (see brackets).

Note: If this is your first High Level Gearbox we recommend you read all notes thoroughly.

1. While the etches are still in the fret, progressively open out the holes to suit the components, so they're a push-fit (see A & B). Remove all burrs.

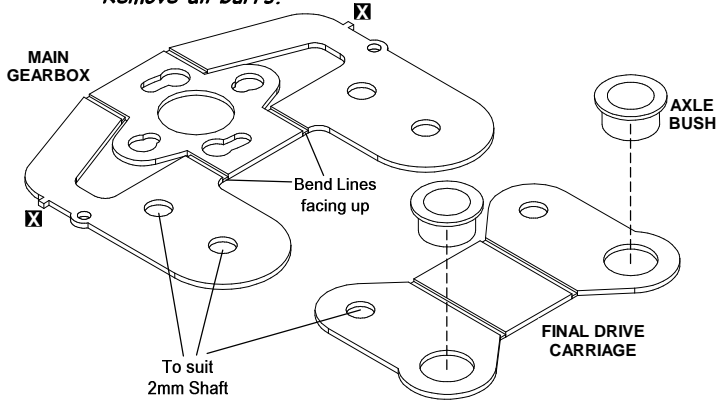

2. Cut the etches from the fret. Take care not to accidentally remove the locators 'X'.

3. Solder in the Axle Bushes, making sure they're fully home. File the bushes to size (see C).

5. Ensure the Carriage fits snugly inside of the main box, clip the Remote Attachment onto 'X' to check the width and then solder a length of wire across the box.

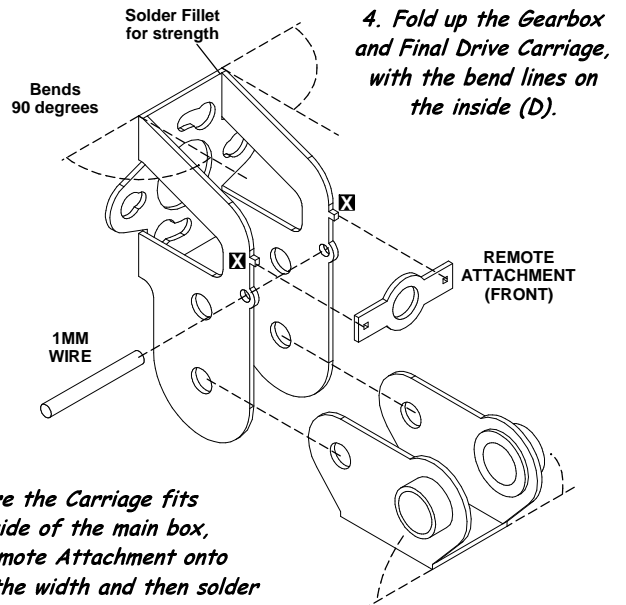

4. Fold up the Gearbox and Final Drive Carriage, with the bend lines on the inside (D).

6. Strengthen all the bends with solder, remove the Attachment and then clean up the etches.

7. Cut the Gearshafts to length (E) then fit the Stage 1 Shaft, Gear and Spacer (F). After checking the gear revolves freely (G) secure the ends of the shaft using a small amount of adhesive. Be careful the glue doesn't stray into the gear itself.

8. Slot the Idler Shaft through its locations in both the Main Gearbox and Carriage. Include the thin Idler Gear and Spacer Washer (raised ring facing the gear).

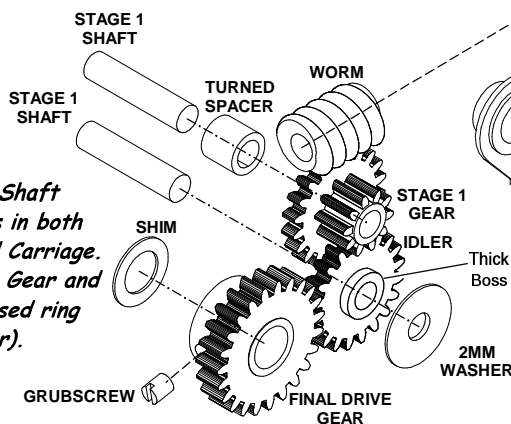

9. The Final Drive Carriage can be sited anywhere on its arc, facing either way, but it must be fixed in place before applying power (Section 'H').

10. Fit the Axle, 23T Gear and Spacer into the Carriage, and Shim as required (read 'J'). Tighten the GrubscREW and check all the gears revolve smoothly.

11. After testing the Motor, push the worm onto the motor shaft (K) so its rear face is 3mm from the Motor face. Secure with Loctite or adhesive.

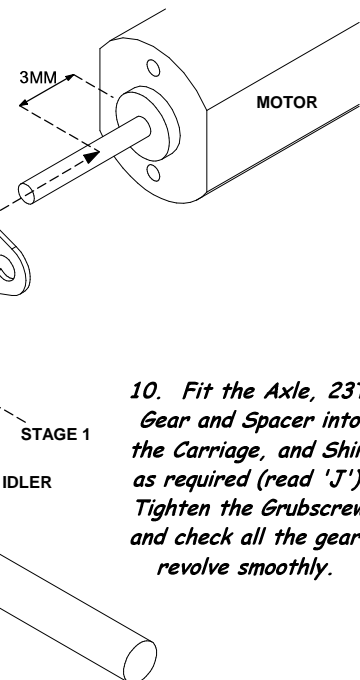

P.T.O. →

## RoadRunner+ 34/45/60:1 Gearbox

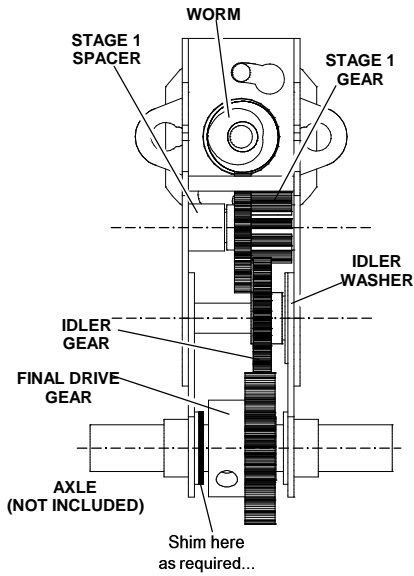

12. Fit the motor/worm assembly, (L) check the mesh (M) and test the gearbox under power. Lightly lubricate the mechanism (N) then the gearbox is ready to fit (C & J).

The kit includes the additional etched components (P) you will need to convert the gearbox into a remote-drive system, using cardan shafts linked to the motor by universal joints.

[www.highlevelkits.co.uk](http://www.highlevelkits.co.uk)

